

TECHNICAL DATA

Three Phase Electric Motors - Cast Iron Frame
 HE30 225 M-6 IE2
 30 kW / 40 Cv
 980 RPM

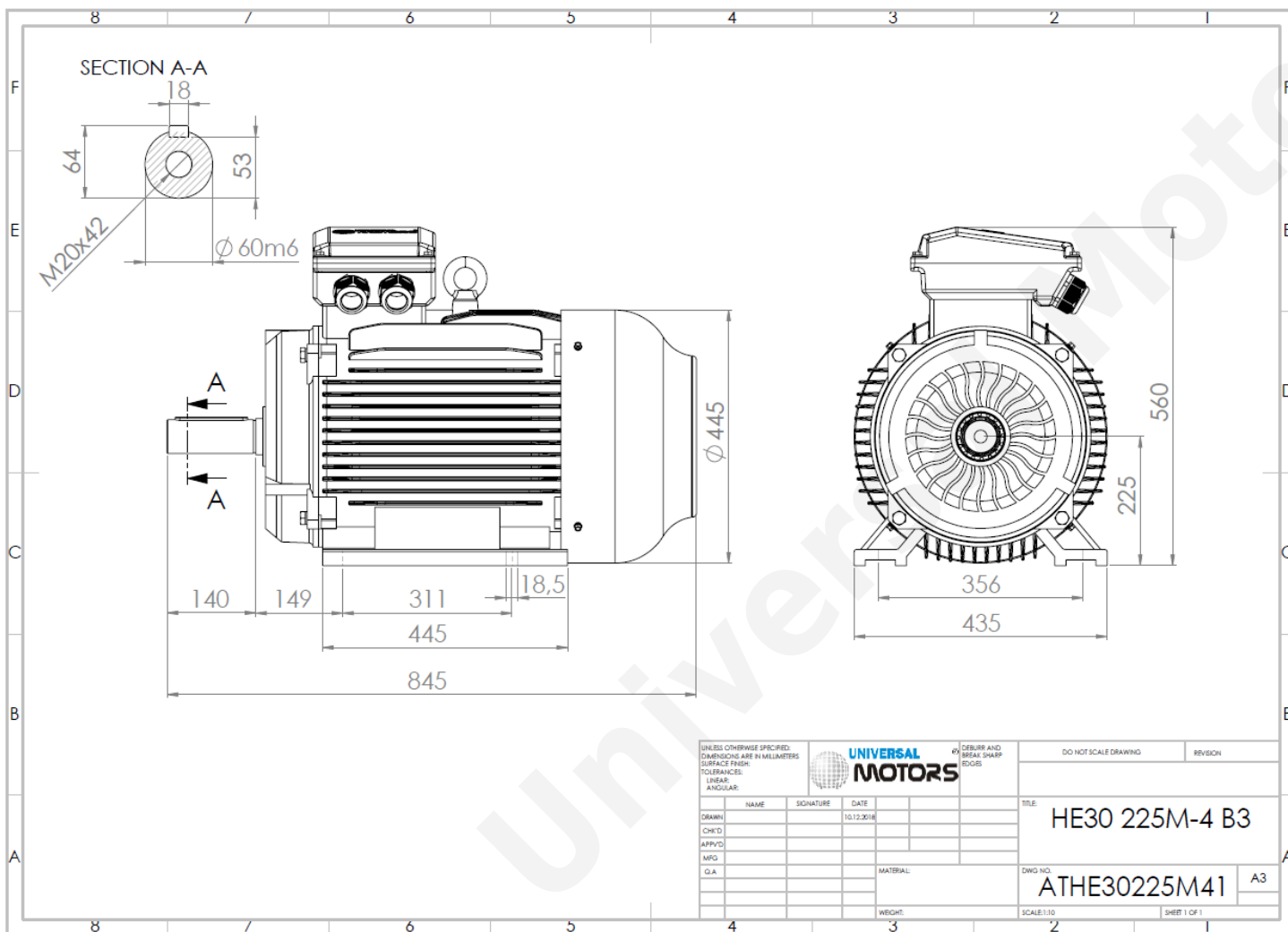

Motor type:	HE30 225 M-6 IE2
Output:	30 kW / 40 Cv
Speed (min^{-1}):	980 RPM
Frequency:	50 Hz
Voltage:	400 V
Current:	57.6 A
Power factor ($\text{Cos } \phi$):	0.82
Poles:	6
Insulation class:	F
Temperature rise Class:	B
Efficiency 50%:	91.4 %
Efficiency 75%:	92.0 %
Efficiency 100%:	91.7 %
Torque:	292 N.m
Tstarting/Tnominal:	2.1
Istarting/Inominal:	7.1
Tmaximum/Tnominal:	2.1
Noise:	65 Db(A)
Weight:	370 Kg
Bearing DE:	6313 C3
Bearing NDE:	6313 C3

Regime - S1

Altitude - 1000m

Environment Temperature - 40°C

CONTACTS:

UNIVERSAL MOTORS Tel: +351 252 299 080
 Rua de São Brás, 745 Fax: +351 252 299 089
 4480-782 VILA DO CONDE Mail: geral@universalmotors.pt

* References applied only in the UK